

→ TWO

“Implement a Duty of Care Policy, which incorporates a driving at work policy”

Let us introduce you to yourself sitting at your desk with your telephone. You are in solid blue because you are doing everything correctly!

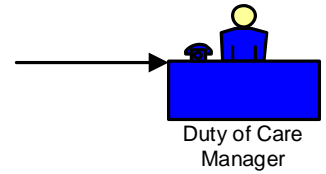

Let us introduce you to your “Company Drivers”. The one in green is “Street Legal” the one in red is not! To stay blue you need all green “Company Drivers”

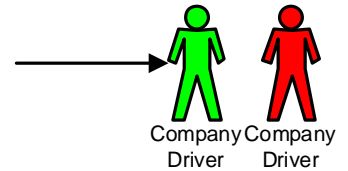

Then you have your “Company vehicles” which you should by now understand has nothing to do with who “Owns” it so just think of it as a “Mobile Office” and keep it in the green!

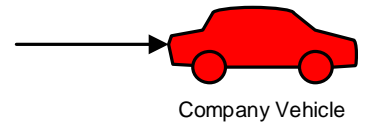
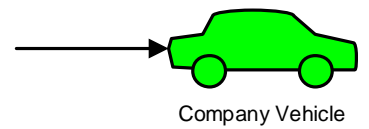

Oops... sorry nearly forgot the only other thing you need to decide is how you will track all the data to remain “Street Legal” either by modern PC software or the old paper filing system or a combination of both!

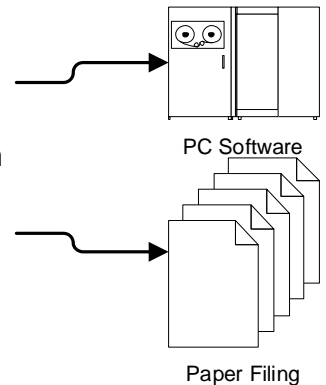

When writing your vehicle duty of care policy you want to see it as an extension of you company policy. It should be seen as complimentary rather than contradictory. Make copies freely available for anybody to read.

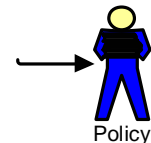

Your Duty of Care policy should include some of the elements shown below



Motoring offences



Regular Health Checks



Cash for Cars



Monitor Driver Safety

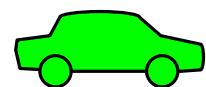

Regular Vehicle Checks